

IEEE Guide on Transformers for Application in Distributed Photovoltaic (DPV) Power Generation Systems

IEEE Power and Energy Society

Sponsored by the
Transformers Committee

IEEE
3 Park Avenue
New York, NY 10016-5997
USA

IEEE Std C57.159™-2016

IEEE Guide on Transformers for Application in Distributed Photovoltaic (DPV) Power Generation Systems

Sponsor

Transformers Committee
of the
IEEE Power and Energy Society

Approved 15 May 2016

IEEE-SA Standards Board

Abstract: General and specific recommendations on specification, design, and application of liquid-immersed and dry-type transformers in distributed photovoltaic (DPV) power generation systems for commercial, industrial, and utility systems are provided in this guide.

Keywords: distributed power generation, electrostatic shield, harmonics, IEEE C57.159™, impedance, inverter, photovoltaic, PV, transformer, winding connection diagram

The Institute of Electrical and Electronics Engineers, Inc.
3 Park Avenue, New York, NY 10016-5997, USA

Copyright © 2016 by The Institute of Electrical and Electronics Engineers, Inc.
All rights reserved. Published 3 November 2016. Printed in the United States of America.

IEEE is a registered trademark in the U.S. Patent & Trademark Office, owned by The Institute of Electrical and Electronics Engineers, Incorporated.

National Electrical Code, NEC, and NFPA 70 are registered trademarks in the U.S. Patent & Trademark Office, owned by the National Fire Protection Association.

PDF: ISBN 978-1-5044-2266-6 STD21080
Print: ISBN 978-1-5044-2267-3 STDPD21080

IEEE prohibits discrimination, harassment, and bullying. For more information, visit <http://www.ieee.org/web/aboutus/whatis/policies/p9-26.html>.

No part of this publication may be reproduced in any form, in an electronic retrieval system or otherwise, without the prior written permission of the publisher.

Important Notices and Disclaimers Concerning IEEE Standards Documents

IEEE documents are made available for use subject to important notices and legal disclaimers. These notices and disclaimers, or a reference to this page, appear in all standards and may be found under the heading “Important Notice” or “Important Notices and Disclaimers Concerning IEEE Standards Documents.”

Notice and Disclaimer of Liability Concerning the Use of IEEE Standards Documents

IEEE Standards documents (standards, recommended practices, and guides), both full-use and trial-use, are developed within IEEE Societies and the Standards Coordinating Committees of the IEEE Standards Association (“IEEE-SA”) Standards Board. IEEE (“the Institute”) develops its standards through a consensus development process, approved by the American National Standards Institute (“ANSI”), which brings together volunteers representing varied viewpoints and interests to achieve the final product. Volunteers are not necessarily members of the Institute and participate without compensation from IEEE. While IEEE administers the process and establishes rules to promote fairness in the consensus development process, IEEE does not independently evaluate, test, or verify the accuracy of any of the information or the soundness of any judgments contained in its standards.

IEEE does not warrant or represent the accuracy or content of the material contained in its standards, and expressly disclaims all warranties (express, implied and statutory) not included in this or any other document relating to the standard, including, but not limited to, the warranties of: merchantability; fitness for a particular purpose; non-infringement; and quality, accuracy, effectiveness, currency, or completeness of material. In addition, IEEE disclaims any and all conditions relating to: results; and workmanlike effort. IEEE standards documents are supplied “AS IS” and “WITH ALL FAULTS.”

Use of an IEEE standard is wholly voluntary. The existence of an IEEE standard does not imply that there are no other ways to produce, test, measure, purchase, market, or provide other goods and services related to the scope of the IEEE standard. Furthermore, the viewpoint expressed at the time a standard is approved and issued is subject to change brought about through developments in the state of the art and comments received from users of the standard.

In publishing and making its standards available, IEEE is not suggesting or rendering professional or other services for, or on behalf of, any person or entity nor is IEEE undertaking to perform any duty owed by any other person or entity to another. Any person utilizing any IEEE Standards document, should rely upon his or her own independent judgment in the exercise of reasonable care in any given circumstances or, as appropriate, seek the advice of a competent professional in determining the appropriateness of a given IEEE standard.

IN NO EVENT SHALL IEEE BE LIABLE FOR ANY DIRECT, INDIRECT, INCIDENTAL, SPECIAL, EXEMPLARY, OR CONSEQUENTIAL DAMAGES (INCLUDING, BUT NOT LIMITED TO: PROCUREMENT OF SUBSTITUTE GOODS OR SERVICES; LOSS OF USE, DATA, OR PROFITS; OR BUSINESS INTERRUPTION) HOWEVER CAUSED AND ON ANY THEORY OF LIABILITY, WHETHER IN CONTRACT, STRICT LIABILITY, OR TORT (INCLUDING NEGLIGENCE OR OTHERWISE) ARISING IN ANY WAY OUT OF THE PUBLICATION, USE OF, OR RELIANCE UPON ANY STANDARD, EVEN IF ADVISED OF THE POSSIBILITY OF SUCH DAMAGE AND REGARDLESS OF WHETHER SUCH DAMAGE WAS FORESEEABLE.

Translations

The IEEE consensus development process involves the review of documents in English only. In the event that an IEEE standard is translated, only the English version published by IEEE should be considered the approved IEEE standard.

Official statements

A statement, written or oral, that is not processed in accordance with the IEEE-SA Standards Board Operations Manual shall not be considered or inferred to be the official position of IEEE or any of its committees and shall not be considered to be, or be relied upon as, a formal position of IEEE. At lectures, symposia, seminars, or educational courses, an individual presenting information on IEEE standards shall make it clear that his or her views should be considered the personal views of that individual rather than the formal position of IEEE.

Comments on standards

Comments for revision of IEEE Standards documents are welcome from any interested party, regardless of membership affiliation with IEEE. However, IEEE does not provide consulting information or advice pertaining to IEEE Standards documents. Suggestions for changes in documents should be in the form of a proposed change of text, together with appropriate supporting comments. Since IEEE standards represent a consensus of concerned interests, it is important that any responses to comments and questions also receive the concurrence of a balance of interests. For this reason, IEEE and the members of its societies and Standards Coordinating Committees are not able to provide an instant response to comments or questions except in those cases where the matter has previously been addressed. For the same reason, IEEE does not respond to interpretation requests. Any person who would like to participate in revisions to an IEEE standard is welcome to join the relevant IEEE working group.

Comments on standards should be submitted to the following address:

Secretary, IEEE-SA Standards Board
445 Hoes Lane
Piscataway, NJ 08854 USA

Laws and regulations

Users of IEEE Standards documents should consult all applicable laws and regulations. Compliance with the provisions of any IEEE Standards document does not imply compliance to any applicable regulatory requirements. Implementers of the standard are responsible for observing or referring to the applicable regulatory requirements. IEEE does not, by the publication of its standards, intend to urge action that is not in compliance with applicable laws, and these documents may not be construed as doing so.

Copyrights

IEEE draft and approved standards are copyrighted by IEEE under U.S. and international copyright laws. They are made available by IEEE and are adopted for a wide variety of both public and private uses. These include both use, by reference, in laws and regulations, and use in private self-regulation, standardization, and the promotion of engineering practices and methods. By making these documents available for use and adoption by public authorities and private users, IEEE does not waive any rights in copyright to the documents.

Photocopies

Subject to payment of the appropriate fee, IEEE will grant users a limited, non-exclusive license to photocopy portions of any individual standard for company or organizational internal use or individual, non-commercial use only. To arrange for payment of licensing fees, please contact Copyright Clearance Center, Customer Service, 222 Rosewood Drive, Danvers, MA 01923 USA; +1 978 750 8400. Permission to photocopy portions of any individual standard for educational classroom use can also be obtained through the Copyright Clearance Center.

Updating of IEEE Standards documents

Users of IEEE Standards documents should be aware that these documents may be superseded at any time by the issuance of new editions or may be amended from time to time through the issuance of amendments, corrigenda, or errata. An official IEEE document at any point in time consists of the current edition of the document together with any amendments, corrigenda, or errata then in effect.

Every IEEE standard is subjected to review at least every ten years. When a document is more than ten years old and has not undergone a revision process, it is reasonable to conclude that its contents, although still of some value, do not wholly reflect the present state of the art. Users are cautioned to check to determine that they have the latest edition of any IEEE standard.

In order to determine whether a given document is the current edition and whether it has been amended through the issuance of amendments, corrigenda, or errata, visit the IEEE-SA Website at <http://ieeexplore.ieee.org/> or contact IEEE at the address listed previously. For more information about the IEEE SA or IEEE's standards development process, visit the IEEE-SA Website at <http://standards.ieee.org>.

Errata

Errata, if any, for all IEEE standards can be accessed on the IEEE-SA Website at the following URL: <http://standards.ieee.org/findstds/errata/index.html>. Users are encouraged to check this URL for errata periodically.

Patents

Attention is called to the possibility that implementation of this standard may require use of subject matter covered by patent rights. By publication of this standard, no position is taken by the IEEE with respect to the existence or validity of any patent rights in connection therewith. If a patent holder or patent applicant has filed a statement of assurance via an Accepted Letter of Assurance, then the statement is listed on the IEEE-SA Website at <http://standards.ieee.org/about/sasb/patcom/patents.html>. Letters of Assurance may indicate whether the Submitter is willing or unwilling to grant licenses under patent rights without compensation or under reasonable rates, with reasonable terms and conditions that are demonstrably free of any unfair discrimination to applicants desiring to obtain such licenses.

Essential Patent Claims may exist for which a Letter of Assurance has not been received. The IEEE is not responsible for identifying Essential Patent Claims for which a license may be required, for conducting inquiries into the legal validity or scope of Patents Claims, or determining whether any licensing terms or conditions provided in connection with submission of a Letter of Assurance, if any, or in any licensing agreements are reasonable or non-discriminatory. Users of this standard are expressly advised that determination of the validity of any patent rights, and the risk of infringement of such rights, is entirely their own responsibility. Further information may be obtained from the IEEE Standards Association.

Participants

At the time this guide was submitted to the IEEE-SA Standards Board for approval, the C57.159 Working Group had the following membership:

Hemchandra Shertukde, *Chair*
Mathieu Sauzay, *Vice Chair*
Aleksandr Levin, *Secretary*

| | | |
|--------------------|--------------------|-------------------|
| Donald Ayers | Christoph Jordaan | Subhas Sarkar |
| Enrigue Betancourt | Sheldon Kennedy | Jeffrey Schneider |
| Michael Craven | Jitendra Mamtora | Sanjib Som |
| Norman Field | Abhinav Mitra | Craig Stiegemeier |
| Carlos Gaytan | Amitav Mukerji | Troy Tanaka |
| Ali Ghafourian | Aniruddha Narawane | Vijay Tendulkar |
| Kenneth Harden | Martin Navarro | Kiran Vedante |
| Philip Hopkinson | Stephen Oaks | Sukdhev Walia |
| Brad Jensen | Branimir Petosic | Jennifer Yu |
| Charles Johnson | Jarrod Prince | Peter Zhao |
| | Amitabh Sarkar | |

The following members of the individual balloting committee voted on this guide. Balloters may have voted for approval, disapproval, or abstention.

| | | |
|------------------------|----------------------|----------------------|
| William Ackerman | Brad Jensen | Joseph Rostron |
| Samuel Aguirre | Charles Johnson | Thomas Rozek |
| Donald Ayers | Laszlo Kadar | Dinesh Sankarakurup |
| Robert Ballard | Sheldon Kennedy | Steven Sano |
| Thomas Barnes | Yuri Khersonsky | Daniel Sauer |
| Wallace Binder | Axel Kraemer | Bartien Sayogo |
| Thomas Blackburn | Jim Kulchisky | Devki Sharma |
| Thomas Blair | Saumen Kundu | Hemchandra Shertukde |
| W. Boettger | John Lackey | Mark Siira |
| Paul Boman | Chung-Yiu Lam | Hyeong Sim |
| Thomas Callsen | Aleksandr Levin | Jeremy Smith |
| Paul Cardinal | Richard Marek | Jerry Smith |
| Arvind Chaudhary | Brian McMillan | Mark Smith |
| Craig Colopy | Mark McNally | Gary Smullin |
| Nancy Connelly | John Miller | Steve Snyder |
| Stephen Conrad | Daleep Mohla | Sanjib Som |
| Mamadou Diong | Charles Morgan | Wayne Stec |
| Dieter Dohnal | Daniel Mulkey | Clayton Stice |
| Gary Donner | Jerry Murphy | Troy Alan Tanaka |
| Cliff Erven | Ryan Musgrove | Susmitha Tarlapally |
| Jorge Fernandez Daher | Ali Naderian Jahromi | Ed TeNyenhuis |
| Fredric Friend | K. R. M. Nair | David Tepen |
| Darrell Furlong | Martin Navarro | Alan Traut |
| Carlos Gaytan | Kris K Neild | James Van De Ligt |
| Frank Gerleve | Michael Newman | Kiran Vedante |
| Ali Ghafourian | Raymond Nicholas | John Vergis |
| David Gilmer | Dhiru Patel | Jane Verner |
| James Graham | Branimir Petosic | Sukdhev Walia |
| Randall Groves | Donald Platts | Reigh Walling |
| Ajit Gwal | Alvaro Portillo | Joe Watson |
| J. Harlow | Leslie Recksiedler | Kenneth White |
| Roger Hayes | John Roach | James Wilson |
| Philip Hopkinson | Michael Roberts | William Wimmer |
| Ruben Inzunza Figueroa | Charles Rogers | Jian Yu |
| | Oleg Roizman | |

When the IEEE-SA Standards Board approved this guide on 15 May 2016, it had the following membership:

Jean-Philippe Faure, *Chair*
Ted Burse, *Vice Chair*
John D. Kulick, *Past Chair*
Konstantinos Karachalios, *Secretary*

Chuck Adams
Masayuki Ariyoshi
Stephen Dukes
Jianbin Fan
J. Travis Griffith
Gary Hoffman
Ronald W. Hotchkiss

Michael Janezic
Joseph L. Koepfinger*
Hung Ling
Kevin Lu
Annette D. Reilly
Gary Robinson
Mehmet Ulema

Yingli Wen
Howard Wolfman
Don Wright
Yu Yuan
Daidi Zhong

*Member Emeritus

Introduction

This introduction is not part of IEEE Std C57.159-2016, IEEE Guide on Transformers for Application in Distributed Photovoltaic (DPV) Power Generation Systems.

Transformers addressed in this guide are for the application in distributed photovoltaic (DPV) power generation systems and generally belong to Class I transformers per IEEE Std C57.12.00 and Category I and II transformers per IEEE Std C57.12.00 and IEEE Std C57.12.01. The guide focuses mainly on the inverter transformers of the DPV power generation systems that are connected to the inverters supplying ac voltage and current to the primary (LV) winding of the transformer.

Presently known nominal voltage of these transformers is up to 36 kV and rated power is up to 4000 kVA. Transformers for DPV systems are gradually increasing in their numbers in the field due to the recent increased focus on renewable energy sources. These transformers are primarily used as step-up transformers but can be used as step-down transformers as well. Transformers for DPV systems have a number of specific issues (requirements and constraints) that affect transformer design and application.

This IEEE guide provides information to support specification, design, and application of these transformers by:

- Explaining concerns and differences of DPV system application and providing specific operation and construction techniques to address these concerns and differences.
- Summarizing these considerations for the engineer specifying the transformer.
- Explaining specifics of transformers working with inverters in this application.
- Providing timely state-of-the-art guidance while critical technical details of these power systems are still evolving.
- Increasing awareness of the constraints of this application aiming at increasing reliability of DPV system transformers.
- Having a single document listing all issues related to the application and reference to the relevant existing standards and guides.
- Avoiding pitfalls and failures as has happened in other new distributed power generation systems applications.
- The words “should” and “may” in this document refer to matters that are recommended or permissive but not mandatory.

Describing and addressing the special needs of the DPV power generation systems, the guide will ensure that the transformers for these systems are effective and reliable and will fulfill a need of the solar energy’s growing place in the renewable energy generation systems.

Contents

| | |
|---|----|
| 1. Overview..... | 10 |
| 1.1 Scope..... | 10 |
| 1.2 Purpose..... | 10 |
| 2. Normative references | 11 |
| 3. Definitions..... | 12 |
| 4. Specifics of DPV power generation systems in relation to a transformer application..... | 12 |
| 4.1 Typical DPV power generation systems and DPV system inverter transformers..... | 12 |
| 4.2 Ambient temperature, weather, and mode of operation—Effect on the system, inverter, and transformer | 15 |
| 4.3 Technical specifics of the DPV power generation systems | 16 |
| 5. Transformer parameters selection and transformer design | 18 |
| 5.1 General design considerations and recommendations | 18 |
| 5.2 Loading, loss evaluation, and efficiency..... | 22 |
| 5.3 Power quality consideration | 23 |
| 5.4 Voltage and insulation coordination | 25 |
| 5.5 Other design consideration | 26 |
| 5.6 Technical requirements of auxiliary transformers | 29 |
| 6. Transformer general requirements, construction, and protection | 29 |
| 6.1 Transformer type | 29 |
| 6.2 Design consideration | 30 |
| 6.3 Construction consideration..... | 30 |
| 6.4 Recommended accessories and gauges placement | 31 |
| 6.5 Arc flash aspects and protection..... | 31 |
| 7. Transformer test, installation, and commissioning..... | 32 |
| 7.1 Testing | 32 |
| 7.2 Installation and commissioning | 32 |
| 8. Transformer maintenance, diagnostic, and monitoring | 33 |
| 9. Transformer specification..... | 33 |
| Annex A (informative) Bibliography..... | 34 |

IEEE Guide on Transformers for Application in Distributed Photovoltaic (DPV) Power Generation Systems

IMPORTANT NOTICE: IEEE Standards documents are not intended to ensure safety, security, health, or environmental protection, or ensure against interference with or from other devices or networks. Implementers of IEEE Standards documents are responsible for determining and complying with all appropriate safety, security, environmental, health, and interference protection practices and all applicable laws and regulations.

This IEEE document is made available for use subject to important notices and legal disclaimers. These notices and disclaimers appear in all publications containing this document and may be found under the heading “Important Notice” or “Important Notices and Disclaimers Concerning IEEE Documents.” They can also be obtained on request from IEEE or viewed at <http://standards.ieee.org/IPR/disclaimers.html>.

1. Overview

1.1 Scope

This guide provides general and specific recommendations on application of step-up and step-down liquid-immersed and dry-type transformers in distributed photovoltaic (DPV) power generation systems for commercial, industrial, and utility systems.

The guide focuses mainly on the inverter transformers of the DPV power generation systems that are connected to the inverters supplying ac voltage and current to the primary (LV) winding of the transformer. Some specifics attributed to the auxiliary power transformers in these systems are also discussed.

Transformers covered in this guide comply with the relevant requirements defined in the IEEE Std C57.12.00 for liquid-immersed and IEEE Std C57.12.01 for dry-type transformers.¹

1.2 Purpose

This document supports a harmonized approach to specification, design, and use of the transformers described in the scope of the guide as a component of a DPV power generation system.

¹Information on references can be found in [Clause 2](#).

The guide supports currently evolving industry of DPV power generation by providing guidance on specification, design, and application of transformers for these systems. This guide also intends to help avoid potential problems caused by improperly defined, missed, and/or misinterpreted points of consideration. Further, it is addressing constraints that are important for the correct specification, efficient design, and reliable application of transformers in DPV power generation systems.

2. Normative references

The following referenced documents are indispensable for the application of this document (i.e., they must be understood and used, so each referenced document is cited in text and its relationship to this document is explained). For dated references, only the edition cited applies. For undated references, the latest edition of the referenced document (including any amendments or corrigenda) applies.

Accredited Standards Committee C2-2012, National Electrical Safety Code® (NESC®).^{2,3}

ANSI C57.12.55, American National Standard for Transformer-Used in Unit Installation, Including Unit Substation—Conformance Standard.

IEEE Std C57.12.00™, Standard General Requirements for Liquid-Immersed Distribution, Power, and Regulating Transformers.^{4,5}

IEEE Std C57.12.01™, IEEE Standard for General Requirements for Dry-Type Distribution and Power Transformers.

IEEE Std C57.12.52™, IEEE Standard for Sealed Dry-Type Power Transformers, 501 kVA and Larger, Three-Phase, With High Voltage 601 to 34500 Volts, Low Voltage 208Y/120 to 4160 Volts—General Requirements.

IEEE Std C57.12.90™, IEEE Standard Test Code for Liquid-Immersed Distribution, Power and Regulating Transformers.

IEEE Std C57.12.91™, IEEE Standard Test Code for Dry-Type Distribution and Power Transformers.

IEEE Std C57.18.10™, IEEE Standard Practices Requirements for Semiconductor Power Rectifier Transformers.

IEEE Std C57.91™, IEEE Guide for Loading Mineral-Oil-Immersed Transformers.

IEEE Std C57.93™, IEEE Guide for Installation of Liquid-Immersed Power Transformers.

IEEE Std C57.94™, IEEE Recommended Practice for Installation, Application, Operation, and Maintenance of Dry-Type General Purpose Distribution and Power Transformers.

IEEE Std C57.96™, IEEE Guide for Loading Dry-Type Distribution and Power Transformers.

IEEE Std C57.110™, IEEE Recommended Practice for Establishing Transformer Capability When Supplying Nonsinusoidal Current.

IEEE Std C57.129™, IEEE Standard for General Requirements and Test Code for Oil-Immersed HVDC Converter Transformers.

²National Electrical Safety Code and NESC are both registered trademarks and service marks of the Institute of Electrical and Electronic Engineers, Inc.

³The NESC is available from the Institute of Electrical and Electronic Engineers (<http://standards.ieee.org>).

⁴IEEE publications are available from the Institute of Electrical and Electronics Engineers (<http://standards.ieee.org>).

⁵The IEEE standards or products referred to in this clause are trademarks of the Institute of Electrical and Electronics Engineers, Inc.

NFPA 70®, 2012 Edition, National Electrical Code® (NEC®).⁶

3. Definitions

Terms used in this document, other than those described in this clause, are defined in the *IEEE Standards Dictionary Online* and IEEE Std C57.12.80 [B8]. Some terms are re-stated for emphasis because of the special application. The *IEEE Standards Dictionary Online* should be consulted for terms not defined in this clause.⁷

auxiliary transformer: A transformer intended to provide power to the auxiliary equipment.

insolation number: A measure of incident solar energy flux per unit area, measured in kilowatt-hours (kWh) per kilowatt peak rating (kWp) year (y) or kWh/(kWp×y).

inverter: A machine, device, or system that changes direct-current power to alternating-current power.

inverter transformer: A transformer that transfers all or portion of the inverter output power to an ac power.

percent impedance: The percent of rated primary winding voltage required to circulate current equivalent to rated kilovoltamperes in the primary winding with all secondary winding terminals short-circuited.

primary winding: The winding on the energy input side.

secondary winding: The winding on the energy output side.

step-down transformer: A transformer in which the power transfer is from a higher voltage source circuit to a lower voltage circuit.

step-up transformer: A transformer in which the power transfer is from a lower voltage source circuit to a higher voltage circuit.

substation collector transformer: A power transformer that transfers electric energy supplied through a number of medium-voltage transformers to a distribution or transmission power grid.

4. Specifics of DPV power generation systems in relation to a transformer application

4.1 Typical DPV power generation systems and DPV system inverter transformers

In case of the DPV power generation system, electrical power is generated by converting solar radiation into direct current (dc) electricity using semiconductors that exhibit the photovoltaic effect. Photovoltaic power generation employs solar panels comprising a string of photovoltaic modules (cells) containing a photovoltaic material, often made of silicon. The photovoltaic modules can typically generate a combined dc voltage of up to 1100 V (dc).⁸ The module manufacturers are working on 1500 V (dc) photovoltaic modules.

Normally, the dc power rating of the photovoltaic array connected to an inverter is substantially greater than the power rating of the inverter; this is referred to as dc/ac power ratio.

⁶The NEC is available from the National Fire Protection Association (<http://www.nfpa.org/>). Copies are also available from the Institute of Electrical and Electronics Engineers (<http://standards.ieee.org/>).

⁷*IEEE Standards Dictionary Online* is available at: <http://ieeexplore.ieee.org/xpls/dictionary.jsp>.

⁸Configuration of the DPV power generation systems is rapidly evolving as are the inverter designs. This guide was based on the current up-to-date information available at the time it was written.

The generated dc voltage is then converted to a three-phase ac voltage using either a three-phase inverter or multiple single phase micro-inverters. The inverter output ac voltage of 50 Hz or 60 Hz is dictated by the level of the photovoltaic module dc voltage. The inverter is subsequently connected to a DPV system inverter transformer. This transformer is sometimes called a medium-voltage (MV) transformer. In this guide, the term inverter transformer is defined in [Clause 3](#) and is used hereafter to describe the DPV system inverter transformer. The term transformer is used when other (non-inverter) transformers on the system are discussed.

The inverter transformer is primarily used as a step-up transformer that changes the input voltage and accommodates the voltage polarity reversal and pulsation taking place in the power inverting process. The output (HV) voltage of the step-up inverter transformer can typically be in the range of up to 36 kV or higher when required. The output voltage of the inverter transformer is further supplied to a collector bus, which can feed a suitable load on the distribution system or will be connected to the substation collector transformer at the utility substation that combines the power output of the multiple distributed sources of generation and steps the voltage up to the local load, distribution, or transmission level. The substation collector transformer typically has nominal power in the range of 20 MVA to 40 MVA with a high voltage of the respective grid level, however, the large scale photovoltaic plants may require a larger substation transformer (up to several hundred megavoltamperes). [Figure 1](#) and [Figure 2](#) illustrate the process of conversion of energy from solar radiation into usable and transmittable ac electrical power using two-winding or three-winding transformers, respectively.

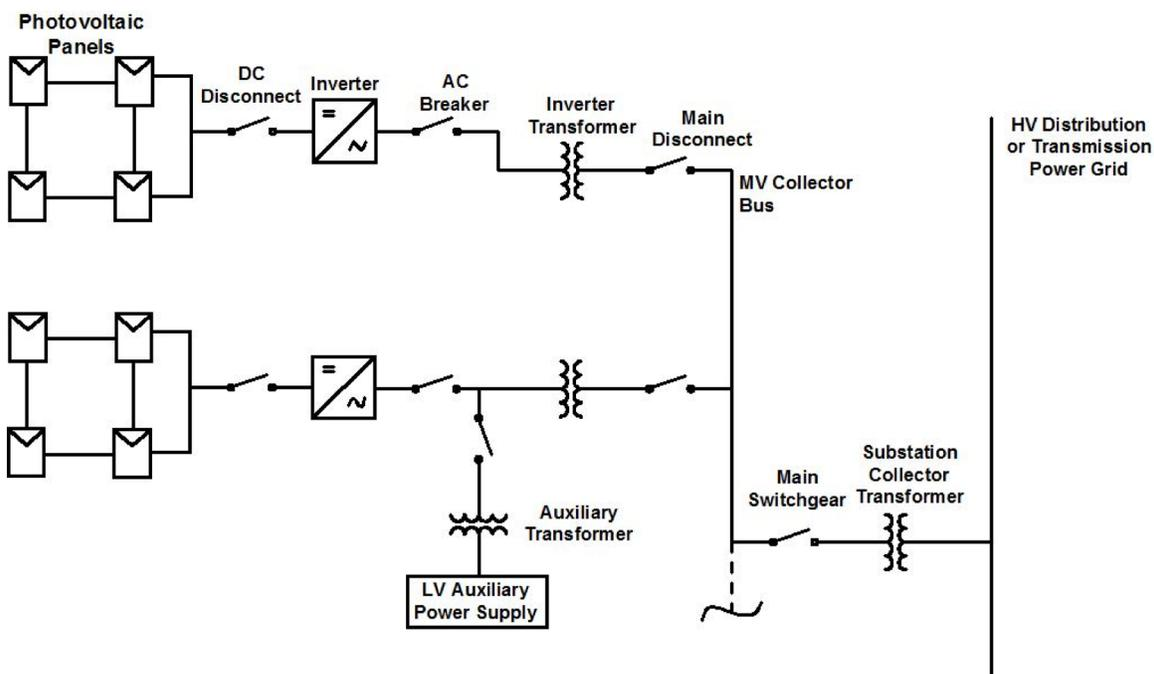

Figure 1—Example of a single line configuration of the DPV power generation system with a three-winding transformer: one inverter feeds one transformer

The inverter transformer can work as a step-down transformer, feeding an auxiliary transformer from the medium voltage grid (usually at night). The flow of energy in the inverter transformer is reversed in this case, compared to the daytime PV power generation process.

The inverter can have an integrated small kilovoltampere rating auxiliary power transformer to supply power to the inverter. Alternatively, a non-integrated external auxiliary power transformer can be used for this purpose. When an additional low-voltage auxiliary power transformer is used (as shown in [Figure 1](#) and [Figure 2](#)), it can be connected to either an electricity grid or to the LV side of the inverter transformer.

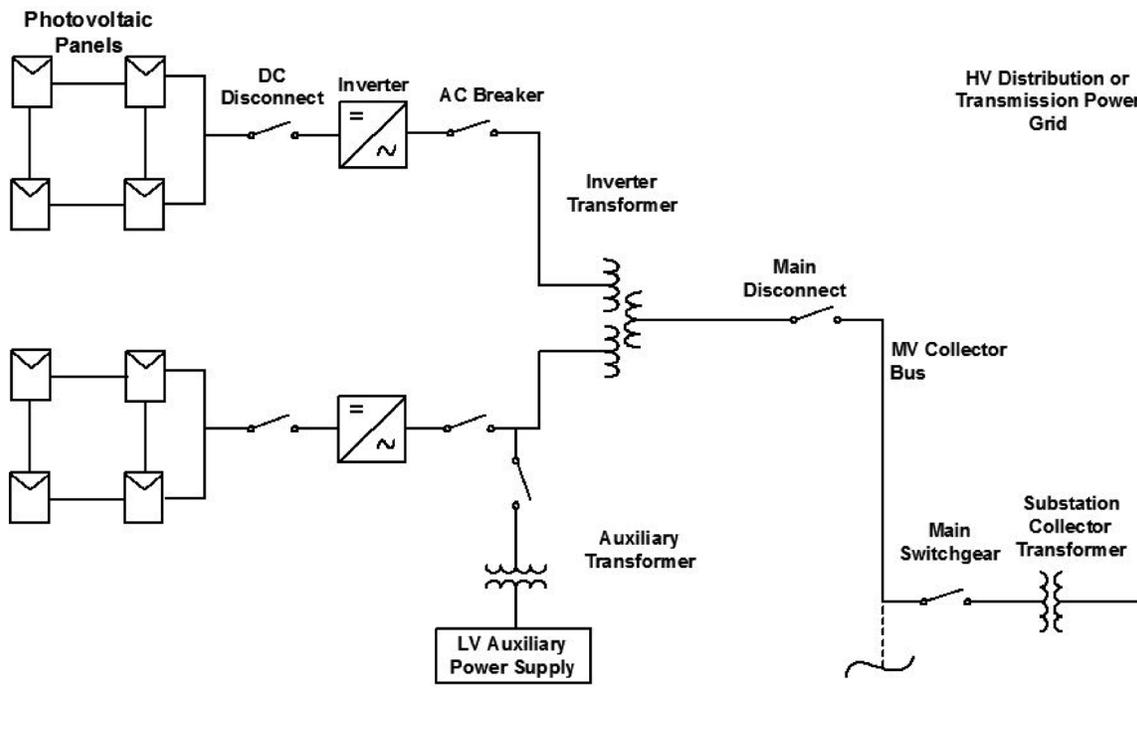

Figure 2—Example of a single line configuration of the DPV power generation system with a three-winding transformer: two inverters feed one transformer

The current harmonic content in DPV power generation systems depends on the inverter-transformer interaction and possible resonances in the system. The harmonic content needs to be specified and taken into consideration by the transformer original equipment manufacturer.

Normally, there is no significant voltage fluctuation in these systems (see 5.3 on power quality consideration). IEEE Std 1547 [B13] provides useful information about the basic standard requirements on voltage, frequency, harmonic current distortion, and islanding for interconnecting distributed resources with electric power systems.

As described previously, different types of transformers can be part of the DPV power generation system: inverter transformers, auxiliary power transformers, and substation collector transformers. This guide is focused mainly on the inverter transformers, but the provided information should be relevant and useful for the specifiers, designers, and end users of the auxiliary power and substation collector transformers on the DPV power generation systems.

The limiting factor for the inverter size is the physical size of the PV array supplying power to the inverter and the distance over which the dc output of the array must be transmitted from the farther extents of the array to the inverter location. PV inverters are currently available with ratings of several MVA. A typical rating of the present inverter modules is 500 kVA. For economic reasons, associated capital expenditures and limited space requirements, many DPV applications use pairs of inverters to feed one multi-winding inverter transformer as shown in Figure 2. Each inverter feeding one multi-winding transformer is operated and regulated independently. Some practical considerations for the specification, design, and application of multi-winding transformers are covered in the following sections of this document.

Increasing the capacity of the DPV power generation system by adding more inverters, feeding one transformer is difficult due to complexities associated with the size of the transformer, increased cost, practicalities of running cabling to convert dc power to alternating-current (ac) power, and overall generation reliability.

4.2 Ambient temperature, weather, and mode of operation—Effect on the system, inverter, and transformer

Parameters of the energy (dc voltage, current) generated by the solar panels depend on the solar irradiation and ambient temperature. The solar panel and inverter system power output varies depending on the ambient temperature and sun angle. As a result, the maximum available dc power may reach its peak in the springtime when the combination of relatively high sun angle and moderate temperatures provides the most favorable conditions. This impacts the inverter output ac power, respectively, and may be considered in the load profile of the transformer. An example of the inverter power output as a function of the ambient temperature is shown in Figure 3. The inverter power output is significantly limited at ambient temperatures above 50 °C.

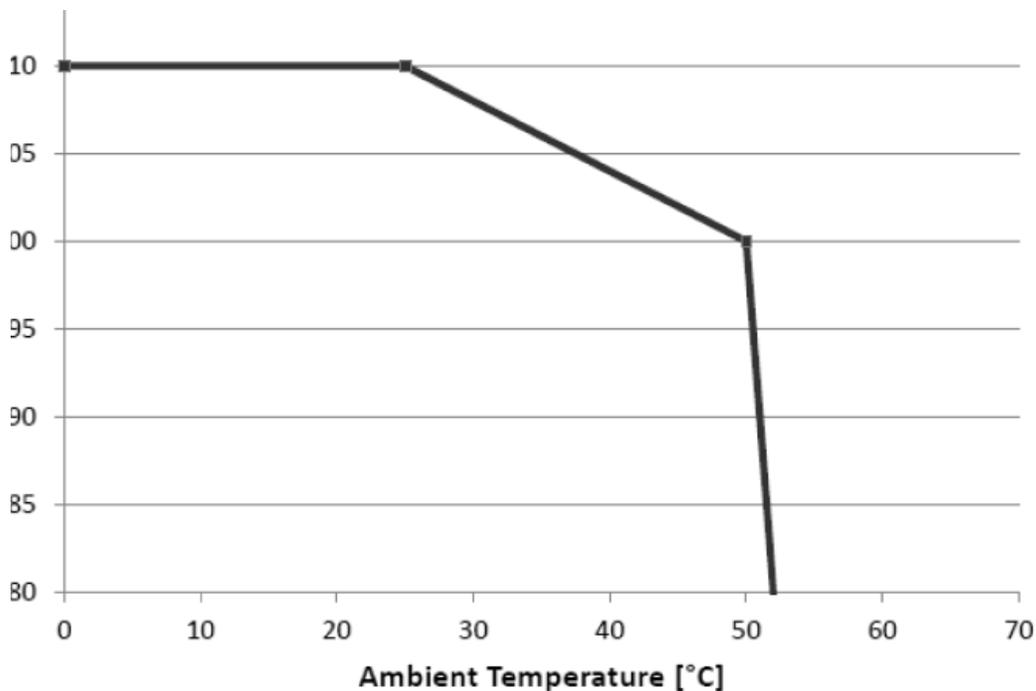

Figure 3—Example of the inverter power output as a function of the ambient temperature

The inverter transformer may be loaded for up to 14 h per day during the summer months, but it might be 100% loaded only for a portion of this time. If the transformer remains energized from the grid during the non-loading hours, the no-load losses are present 24 h per day.

There may be a spike of solar energy associated with a so-called “white cloud” weather pattern; this phenomenon is caused by an amplification of the solar irradiance prior to or following a cloud shadow passage and is related to the reflection of sunlight off the sides of clouds. Consideration of the duration and amplitude of such power spikes may be given in determining whether they affect the transformer kilovoltampere rating as the spikes may have durations substantially shorter than the thermal time constant of the transformer parts. It is recommended that the user provides the data needed for the assessment of this phenomenon.

During the day, the inverter can run active power and reactive power; during the night, the inverter can operate in no-load mode or run reactive power. Depending on the mode of the system operation, examples of a typical load profile of an inverter transformer for a daytime operation and day and nighttime operation are presented in Figure 4. The DPV power generation system may include power storage facility (battery bank); in this case, the inverter transformer can operate at close to a nominal output for 24 h per day.

4.3 Technical specifics of the DPV power generation systems

It is recommended that the inverter manufacturer and transformer manufacturer review options of the inverter transformer configuration and operating conditions based on the planned system design and installation at the initial design stage and later as appropriate. The verification of some of those conditions is difficult to perform in a laboratory test environment and might require actual field experimentation.

4.3.1 Non-symmetrical load and voltage

In case of a three-winding inverter transformer, it is normal that only one of the two inverters connected to that transformer is active and the others are de-energized. It is recommended to design the inverter transformer for operation when only one of the two low voltage windings fully loaded while the other winding is just slightly or not loaded for an extended period of time.

Unbalanced currents from the inverter circuits may cause an unusual flux pattern creating higher than expected heating in windings. Unbalanced voltages from the inverters can cause core or winding heating, excessive core noise, and possible core saturation, hence, elevated excitation current and core temperature.

4.3.2 DC bias

As described in IEEE Std C57.110, harmonic load currents are frequently accompanied by a dc component in the load current. The dc current may only exist in the input winding connected to the inverter as dc current cannot be transformed. A dc component of load current affects the transformer core loss slightly but it can increase the magnetizing current and audible sound level more substantially. Significant increase in the magnetizing current can saturate the core, which may result in increased core temperature and circulating currents in structural parts. In liquid-filled transformers, higher core temperature may lead to generation of hydrogen gases. Relatively small dc components (up to the rms magnitude of the transformer excitation current at rated voltage) are expected to have no effect on the load carrying capability of a transformer determined by this guide. Higher dc load current components may adversely affect transformer capability, and it is recommended to avoid them. It is important that the estimate of the expected dc current is included in the transformer specification for the transformer manufacturer to account for its effect on the transformer design.

The saturation of the core is also an important aspect to consider because of a possibility of a resonance in the case of a cable-connected pad-mounted transformer. Nonlinear self-inductance of the transformer and capacitances connected in the system (such as cable capacitance and filter capacitance of the inverter) may contribute to cause a resonance (when the transformer core is saturated due to the dc bias).

IEEE Std 1547 [B13] limits dc current to 0.5% of rated output current.

4.3.3 Potential inverter and system faults and their impact on the transformer

Grid failures (e.g., disconnection of inverter) can lead to a load fluctuation and nonsymmetry.

The waveform of each of the inverters might not be in complete synchronization, which can cause a disturbance to the transformer magnetic flux, changing its magnitude, wave shape, and harmonic content. The dc voltage component may appear and can saturate the core increasing a no-load current and voltage drop.

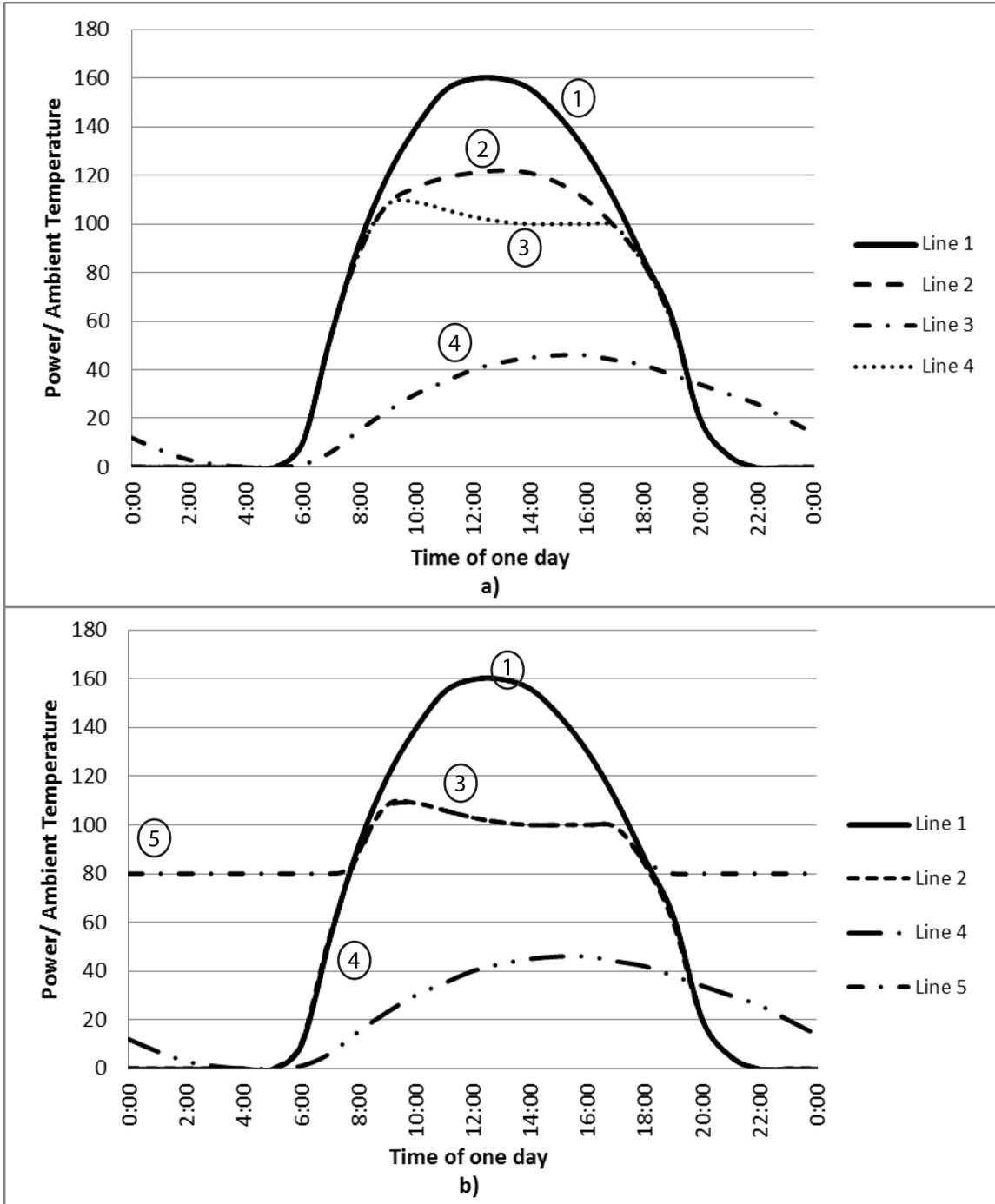

- 1 Generated dc power (% of nominal inverter power)
- 2 Inverter ac power (% of nominal inverter power)
- 3 Transformer active load (% of nominal transformer power)
- 4 Ambient temperature (°C)
- 5 Transformer reactive load (% of nominal transformer power)

NOTE—The graphs do not depict a short-term load fluctuation due to weather effects like shadows, etc.

Figure 4—Example of inverter transformer load profile: a) Day-time operation only (active load only) and b) daytime and nighttime operation (active and reactive load)

The effect of a so-called low-voltage fault ride-through in the photovoltaic energy generation systems is still under investigation, but users need to be informed on the phenomena. An example of such studies is presented by Shertukde [B20].

It is recommended to consider the ground fault effect on the transformer.

5. Transformer parameters selection and transformer design

5.1 General design considerations and recommendations

In general, the design, construction, and testing of rectifier and inverter transformers are covered in IEEE Std C57.18.10. The specifics of DPV power generation system transformers are discussed in this guide.

Transformers for DPV power generation systems can be a liquid-immersed type or dry-type. Normal service conditions of the transformer application are as per IEEE Std C57.12.00 for the liquid-immersed transformers and per IEEE Std C57.12.01 for dry-type transformers. The unusual service conditions are addressed following the respective standards and the recommendations of this guide. If specified, the transformers can be designed and constructed to meet special seismic requirements.

Because practicality limits the PV array area that can be connected to a single inverter, there may be multiple inverters employed at each DPV power generation system. Some users would consider having multiple LV windings in a single transformer with each LV winding connected to an inverter. Design considerations, such as impedance and short circuit, for the transformer with multiple LV windings result in a more complex transformer.

5.1.1 Rated output kVA

The transformer is rated based on the inverter output, load diagram, and specific consideration (harmonic content, weather patterns, unusual service conditions, etc.) and is suitable for the operation with the expected continuous maximum required load. Additional spare capacity for future load growth may also be considered if necessary information is specified.

The system load profile depends on the size of a photovoltaic generation and on the solar irradiation (reduced irradiation leads to load reduction). In the event of no-load operation during a night, the user may define the reduced transformer loading based on the station auxiliary load estimates. Involvement of the transformer design specialist is recommended for this evaluation.

Many inverters are capable of delivering more power than their nameplate kVA rating. It is recommended to rate the inverter transformer at least equal to an expected maximum of the inverter output rating. Rating of the transformer can be further defined by taking into account the predictable energy generation cycle and transformer loading capabilities (IEEE Std C57.91 and IEEE Std C57.96 for liquid-immersed and dry-type transformers, respectively).

Example of the typical three-phase transformer continuous kVA rating: 75 kVA, 112.5 kVA, 150 kVA, 225 kVA, 300 kVA, 500 kVA, 750 kVA, 1000 kVA, 1500 kVA, 2000 kVA, 2500 kVA, 3000 kVA, 4000 kVA.

5.1.2 Nominal voltage

AC waveforms produced by the inverter are generally sinusoidal, however, a waveform of voltage to ground has a pulsed nature; some harmonics and spikes are also present. Figure 5 shows an example of the inverter output ac voltage. The inverter transformer needs to be designed to work with the pulse voltage shape of the inverter.

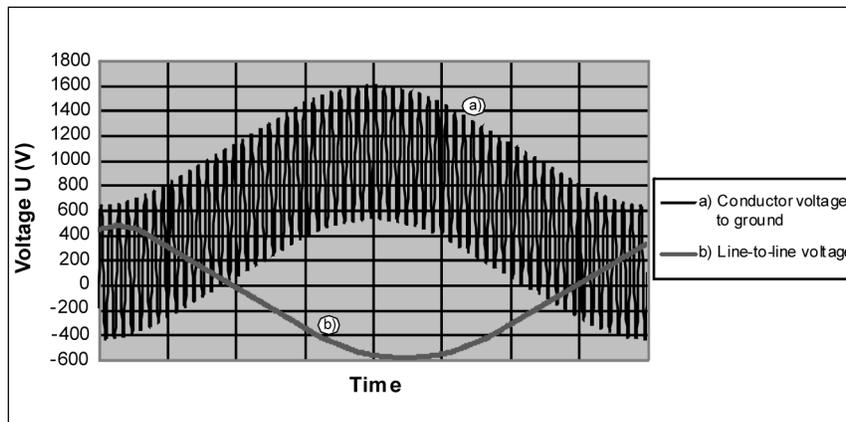

Figure 5—Example of the inverter output ac voltage

Primary (LV) winding voltage is defined by the inverter ac output voltage. Typical primary (LV) winding nominal voltages (phase-to-phase), V: 208, 240, 277, 315, 375, 480, 575, 600 and 690.

Secondary (HV) winding voltage is defined by a grid operator or chosen by the user. Example of the typical secondary (HV) winding nominal voltages (phase-to-phase), V: 12 470, 13 200, 24 940, 34 500.

5.1.3 Transformer voltage regulation

The output voltage of a transformer can be adjusted by a tap changer [typically, a de-energized tap changer on the secondary (HV) winding of the inverter transformer] in order to match its secondary (HV) winding voltage level with the grid voltage. Further, the solar panel deterioration over time might require primary (LV) voltage adjustment (e.g., multiple taps on LV side for a smoother voltage adjustment). A de-energized tap changer (DETC) with a range of +/- 5% of the HV winding nominal voltage is recommended; other types of regulation can be specified as needed.

Depending on the short-circuit power of the grid (active R and reactive X grid impedances), the voltage level could be mainly impacted (specifically, increased) with the inverter reactive power feed-in. Active power feed-in has a low impact on the voltage level.

In case an inverter step-up transformer is required to perform a voltage step-down function, it is recommended that the transformer has a reverse power flow capability. Typically, the reverse power flow is not a problem for the step-up transformers.

5.1.4 Winding connection diagram and vector group

The inverter operation is not affected by the inverter transformer vector group (Dy1, Dy5, or Dy11 will make no difference). No neutral connection is required on the primary (LV) side of the transformer. If a neutral point of the primary (LV) winding is available, it is recommended that this neutral point is neither grounded nor connected to other ground points. On the secondary (HV) side, the inverter transformer can have an isolated neutral point or resonant grounding or low resistance grounding.

As an example, the following winding connection diagrams and vector groups can be used (the diagrams are defined for the step-down operation conditions): two-winding design – Dy1, YNd1, YNy0; three-winding design – Dy1y1, YNd1d1, YNy0y0. In three-winding transformer, it is recommended that the primary voltages and respective excitation currents of both LV windings are in phase with each other, therefore only identical winding connection diagrams can be used for two LV windings (2 “Y” or 2 “D”). An example of the three-winding connection diagram is shown in [Figure 6](#).

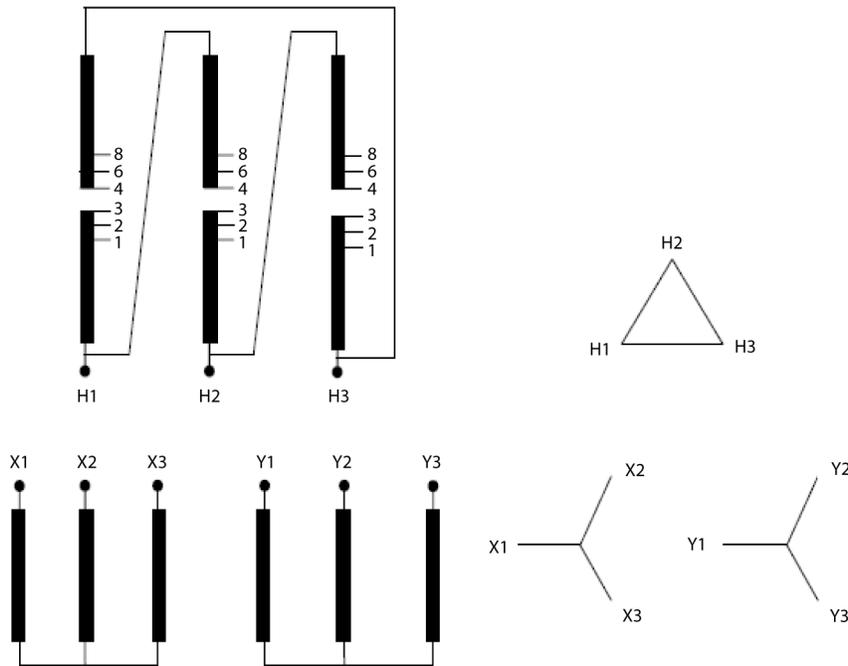

Figure 6—Example of the three-winding transformer connection diagram

5.1.5 Winding configuration and impedance requirements

5.1.5.1 Two-winding transformer

In a two-winding transformer, one primary (LV) winding is fed by one inverter or several inverters working in parallel. The parallel operations of the inverters depends on the type of inverters and is typically used for the smaller kVA inverters.

It is recommended that the user specifies the nominal impedance(s) and acceptable impedance tolerance. Unless otherwise specified, it is recommended that the test impedance tolerance is per the referenced IEEE Standard.

Recommended range of the impedance (at the full rated kVA): 4 to 7% with a tolerance of $\pm 7.5\%$ as per IEEE Std C57.12.00 and IEEE Std C.57.12.01. The specific requirements need to be agreed upon between the user and the manufacturer.

5.1.5.2 Three-winding transformer

In a three-winding transformer, two primary (LV) windings are typically fed by two separate inverters. Inverter design often requires a separate galvanically isolated primary (LV) windings. The parallel operation of several inverters connected to one LV winding is not typically used with large kVA inverters.

It is recommended to consult with the inverter manufacturer to review the parallel operation of the inverters for both two-winding and three-winding transformers.

There are several impedances that might need to be defined for these transformers: L1L2-H (both LV windings are short-circuited, HV winding is energized), L1-H and L2-H (one LV winding is short-circuited, HV winding is energized), L1-L2 (one LV is short-circuited, other LV winding is energized). Normally, it's important to have a close coupling and equal impedances of each of LV winding to the HV winding (in all configurations of

the windings). On the other hand, it is recommended to have high enough impedance between two LV windings in order to decouple these windings.

If specified, it's recommended to measure the L1-L2 impedance rather than define it with a calculation. For example, test method as per 9.3.2 of IEEE Std C57.12.90 and IEEE Std C57.12.91 can be utilized. The acceptable current during L1-L2 impedance test is recommended to be no less than 50% of the nominal current of L1 or L2 winding.

The absolute difference between L1-H and L2-H impedances is recommended to be no more than 2% of the impedance value. The L1-L2 impedance is recommended to be no less than 8% (based on the half of the nominal transformer kVA rating).

Specific values need to be defined and agreed upon between the user and the manufacturer. If tolerance on the impedance was not specified, it is recommended to follow IEEE Std C57.12.00 for liquid-immersed transformers and IEEE Std C57.12.01 for dry-type transformers.

Examples of the several possible winding configurations of the three-winding transformer are shown in Figure 7. The location of a ground shield is proposed and discussed in 5.4. Comments on the potential advantages and disadvantages of these configurations are provided in Table 1.

Table 1—Three-winding transformer winding configuration consideration

| Winding arrangement as in Figure 7 | Winding arrangement type | Impedances to be specified, if required | Advantages | Disadvantages |
|------------------------------------|--|---|--|---|
| a) | Concentric windings (L1-H-L2) | - L1L2-H at full kVA base - L1-H, L2-H, L1-L2 at half-kVA base | - L1-L2 impedance is high - Compact design | L1H and L2H impedances are different between each other |
| b) | Concentric windings with vertically interleaved LV (L1/L2-H) | | - Both L1-H and L2-H impedances are close to each other - Compact design | L1-L2 impedance is relatively low |
| c) | Stacked LV winding (L1-L2-H) | | - Both L1-H and L2-H impedances are close to each other - L1-L2 impedance is high | Less compact design |
| d) | Split stacked LV winding (L1/L2-H) | | Both L1-H and L2-H impedances are close to each other | - Less compact design - L1-L2 impedance is relatively low |
| e) | Horizontally interleaved LV winding (L1/L2-H) | | Both L1-H and L2-H impedances are close to each other | - L1-L2 impedance is low - Insulation requirements between L1 and L2 can make this design non-economical |

The load and the temperature distribution in the parts of the windings depend on the selected configuration and are important to consider for a long-term reliable performance of the transformer. For example, the average and maximum temperatures of the upper stack of identically designed stacked windings (Figure 7c) are higher than the temperatures of the lower stack at the same loading.

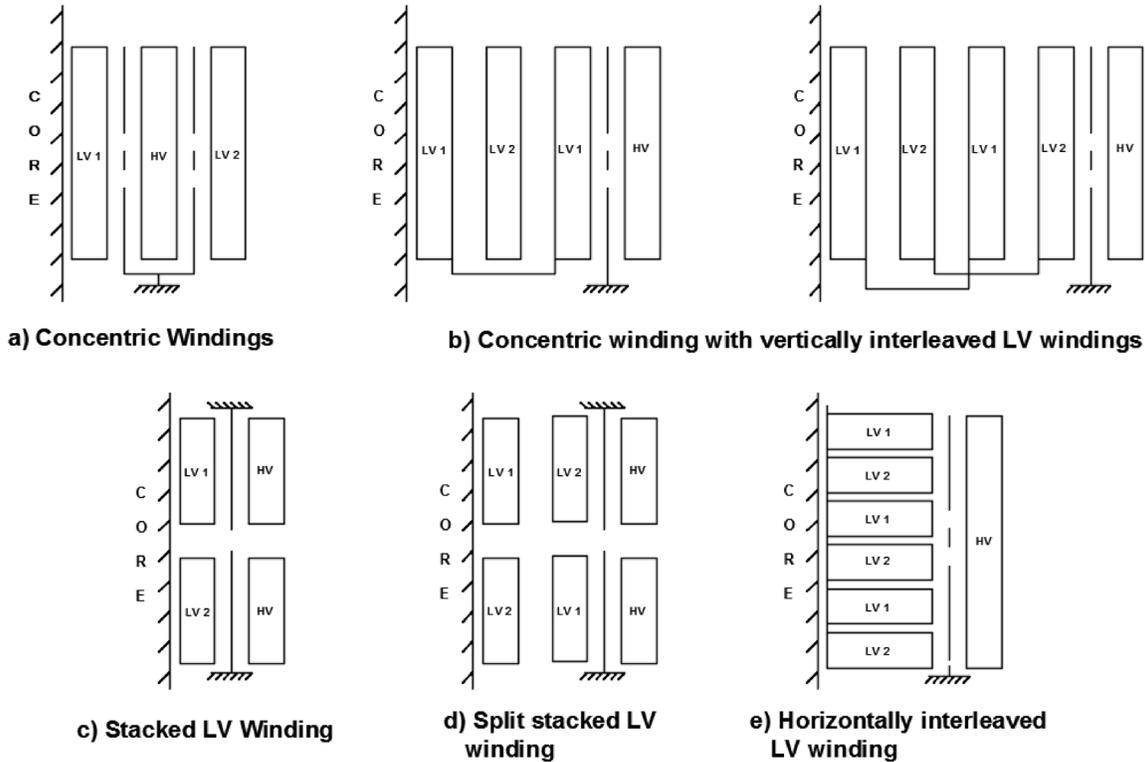

Figure 7—Examples of possible winding configurations of the three-winding transformer

5.2 Loading, loss evaluation, and efficiency

5.2.1 Transformer load and effect of a daily load fluctuation, energization/de-energization

Several aspects of the application need to be considered in the design of transformers for the DPV power generation systems:

a) Load cycling and variability

Typical inverter load profiles are shown in Figure 4. However, the graphs do not depict the load fluctuation due to the solar irradiation fluctuation because of weather effects like shadows, etc. The solar irradiation is defined by the insolation number in a particular location. These effects are more pronounced in the moderate climate location and may be less noticeable in the desert-like climate.

Typically, the weather effects occur during the day-time operation and can create a short-term power fluctuation (for example, power can vary between 20% to 100% of the nominal power with periods of 5 min to 10 min). The load fluctuation of this duration tends to be dampened because of the thermal time constant of the transformer components.

During the peak time of the annual solar activity, the transformer may be fully loaded for 6 hours per day, but it can be unloaded for close to 12 hours when only no-load losses are present. The described above day-time fluctuation of the load in conjunction with the unloading of the transformer at night-time can cause a considerable thermal and mechanical force cycling and may adversely affect the transformer.

The thermal design of the inverter transformer needs to consider the temperature dependent performance of the inverter (see Figure 3). At ambient temperature of up to + 25 °C, the maximum current of the inverter transformer is 110% of the nominal current. At ambient temperatures between + 25 °C

and + 50 °C, a linear derating of the power from 110% of nominal down to the nominal inverter power takes place.

The transformer needs to be designed for long term operating conditions with an asymmetrical load on the primary (LV) side, i.e., in case of three-winding design, the transformer needs to operate reliably with only one inverter supplying power to only one LV winding.

b) Load and mechanical forces

Normally, the transformer is energized and de-energized multiple times during commissioning and maintenance. In addition, daily energization/de-energization of a transformer (for example, switching off at night for loss savings) could lead to additional mechanical and electrical stresses on the transformer and needs to be considered in the transformer design.

c) Reactive load

Modern inverters are able to provide reactive power during a night so the inverter is working as a capacitor or an inductor. This means that a power conversion on the transformer will also occur during a night. The additional reactive power provision can be up to 30% of the maximum inverter power.

5.2.2 Loss evaluation and recommendation on the efficiency

In case of the no-load operation at night, DPV inverter transformers are subject to long-term no-load operation conditions. The long-term no-load losses might have a negative impact on loss capitalization that customer usually takes into account but may also impact the transformer design. Depending on the expected efficiency over a typical daily load cycle, the no-load loss requirements might be different compared to the standard distribution transformer applications. If battery energy storage system was employed at night, the transformer might operate with some load at night.

Currently DPV inverter transformers are exempt from US Department of Energy distribution transformers efficiency regulation [B4].

Often all losses between the inverter ac terminals and the medium voltage switchgear are considered by the user for the analysis of the system efficiency; in this case the transformer efficiency is only a part of the total system. The example of this approach can be found in the California Energy Commission (CEC) Document [B3].

5.3 Power quality consideration

The following standards discuss and address different aspects of the power quality in power generating systems, including systems with energy conversion: IEEE Std 1547 [B13], IEEE Std 519 [B12], IEEE Std C57.18.10, IEEE Std C57.91, IEEE Std C57.110, IEEE Std C57.116 [B9], IEEE Std C57.129, and UL 1741 [B21].

5.3.1 Voltage flicker/variation

DPV power generation system inverter transformers normally operate with a stable voltage controlled by the inverters. Therefore, voltage fluctuations are considerably reduced. The voltage variation is generally in the range of $\pm 5\%$ of the nominal voltage rating. Thus, standard design considerations for transformer insulation design can be applied.

IEEE Std 519 [B12] establishes limits for an allowable commutation notch depth introduced by power converters at critical points of power system, normally coinciding with the points of the inverter transformer location.

5.3.2 Frequency variation

Since the frequency variation can only come from the network, no difference between the design of the inverter transformer and a “standard” power transformer is expected in this regard.

5.3.3 Current harmonics/wave form distortion

The following standards discuss and address different aspects related to the current harmonic content:

- IEEE Std C57.129 sufficiently describes the requirements to the system designer to provide information on the harmonic content and the current waveform, including the cases where there is more than one inverter connected to the transformer windings on the same core leg.
- IEEE Std C57.129 and IEEE Std C57.18.10 use a definition of kVA rating based only on the fundamental frequency; additional losses due to the harmonic content are taken into account during heat-run test.
- IEEE Std C57.110 recommends the practice to establish a transformer capability when supplying non-sinusoidal load current.
- IEEE Std 519 [B12] establishes limits for allowable harmonics levels in power systems. The current distortion limits for general distribution systems (120 V through 69 000 V) are set as a function of the short-circuit ratio and the harmonics order.

Depending on the DPV inverter type, the typical harmonic current content is less than 5%. The relatively low harmonic profile in the DPV power generation system is due to the filtering provided in the inverters to meet interconnection requirements. The relatively high switching frequency of modern inverters requires relatively small filters to achieve acceptably low harmonic output distortion. Unless otherwise specified, harmonic content is expected to be maintained at or below levels described in IEEE Std 519.

However, the inverter-transformer interaction and potential resonances in the system could generate the harmonics with amplitudes and frequencies that can be destructive to the transformer, for example, higher than recommended maximum harmonic current (as a reference, Table 2 provides the recommendations from IEEE Std 1547 for the individual harmonic content):

Table 2—Three-winding transformer winding configuration consideration

| Individual harmonic order h (odd harmonics) ^a | $h < 11$ | $11 \leq h < 17$ | $17 \leq h < 23$ | $23 \leq h < 35$ | $35 \leq h$ | Total demand distortion (TDD) |
|--|----------|------------------|------------------|------------------|-------------|-------------------------------|
| Percent (%) | 4.0 | 2.0 | 1.5 | 0.6 | 0.3 | 5.0 |

^aEven harmonics are limited to 25% of the odd harmonics limits above.

In three-winding transformers, where each of two LV windings are fed by the separate dedicated inverter, the effect of resonance can occur in case time of the switching operation of the insulated gate bipolar transistor of those inverters is not synchronized. If a possibility of such switching asynchronization is expected, it is recommended, in coordination with the inverter manufacturer, to evaluate the transformer resonant characteristics to avoid the destructive effects.

The harmonic content and the reference to the harmonic factor need to be included in the transformer specification for the transformer design consideration.

5.3.4 Power factor variation and regulation

Power factor correction is typically required by the user. It is possible for some inverter designs to produce full reactive power during night periods (100% inductive or capacitive power at some percent of the nameplate rating) that can feed some auxiliary devices.

Varying power factors need to be considered, including possible different power factor output from each inverter.

The user is responsible for designing the system and specifying the inverter transformers to allow transmission of the maximum active power and supply/absorb reactive power. Power factor requirements are recommended to be included in the transformer specification. Additional information on the power factor consideration can be found in IEEE Std C57.12.00 and IEEE Std 62 [B11].

5.4 Voltage and insulation coordination

5.4.1 Transient overvoltage

LV side transients are controlled with the design of the high frequency inverters. Nothing special is required for the LV side design with the exception of the electrostatic shield that might be specified by the inverter manufacturer and user (see 5.5.4).

Transients on the HV side may occur due to multi-stage capacitor bank switching or from the circuit breaker operation. Current chopping and related re-ignition transients could lead to switching-induced problems: resonance failures due to load-breaker interaction or single phase switching.

With the advent of vacuum and gas insulated (SF6) circuit breakers, the phenomenon of the contact re-ignition has caused some transformer failures. The installation of some protection circuits can be considered (to be connected either to a transformer or to a circuit breaker) in order to eliminate spike re-ignition of the contacts.

If a user requires frequent switching operations, it is advised to provide a system model in order to allow for power quality study by modeling or direct measurements in the similar systems. The requirements on the transient process are recommended to be included in the specification. Some recommendations on the analysis and protection can be found in IEEE Std C57.142 [B10]. The requirements to the standard tests proving a performance of the transformer in these conditions need to be provided.

5.4.2 Insulation coordination

It is recommended that the user performs the insulation coordination of the transformer and the system.

IEEE Std C57.129 provides the specific recommendations on the insulation test levels for the converter transformers.

IEEE Std C57.18.10 provides specific recommendations on the insulation design and test levels of rectifier and inverter transformers.

When a three-winding inverter transformer is connected to the insulated gate bipolar transistor pulse width modulated inverter circuit, voltages between LV1 and LV2 can be higher than nominal dc voltage [for example, 800 V (dc) voltage may correspond to up 1200 V (ac) voltage between LV windings]. Correct specification of the L1-L2, L1-H, L2-H, and L1-L2-H test voltages is important and is carefully considered in the insulation system design with the different winding configurations.

As DPV project scale has increased and moved from distribution to transmission levels, 34 500 V secondary (HV) winding voltage has become common; users can consider specifying the increased test voltages (for ex-

ample, of the next higher voltage class) in order to compensate for the possible transient overvoltage, voltage wave form distortion, and other potential power quality aspects.

Full phase-to-phase insulation (protection against ground faults) is recommended.

5.5 Other design consideration

5.5.1 Losses, eddy current and stray losses

When maximum losses are specified, the load profile needs to be considered as well as differences between characteristics of liquid-immersed and dry-type transformers.

In case a harmonic correction needs to be considered, refer to the procedure to determine the total load losses as described in IEEE Std C57.129.

Eddy currents and stray losses are present in every transformer. The majority of stray and eddy losses are due to the fundamental frequency currents, however, the eddy and stray losses can increase in the presence of the significant harmonic content. If the inverter feeding the power into the inverter transformer is producing more than a standard level of harmonics, the stray and eddy losses will increase. The effect of these increased load losses on the efficiency is not typically a concern. Of much greater concern is a possible increase in the windings' hot spot temperature and hot spots in metallic parts. The increased hot spots can reduce the transformer life. Localized extreme overheating can result in a catastrophic transformer failure. Increasing the transformer power rating reduces the load losses at operating current and may compensate for the higher operating temperatures that occur in this situation.

Special attention is needed to the eddy and stray losses in multi-winding configurations in case of any appreciable difference in the load between LV windings. The stray losses in the electrostatic shield can lead to the temperature increase above insulation thermal class limits.

5.5.2 Short-circuit consideration

Transformer short-circuit rating is based on the maximum short-circuit current under all operating conditions and takes into account transformer voltage regulation.

Short-circuit impedance values for the transformer design are recommended to be included in the transformer specification. The purpose of short-circuit impedance requirements is to limit short-circuit current values to what is tolerated by the system and the inverter, as well as the transformer.

The following are possible short-circuit situations in the DPV power generation system:

- a) Short-circuit on the high voltage side of the inverter transformer between the transformer and a power grid (Figure 8).

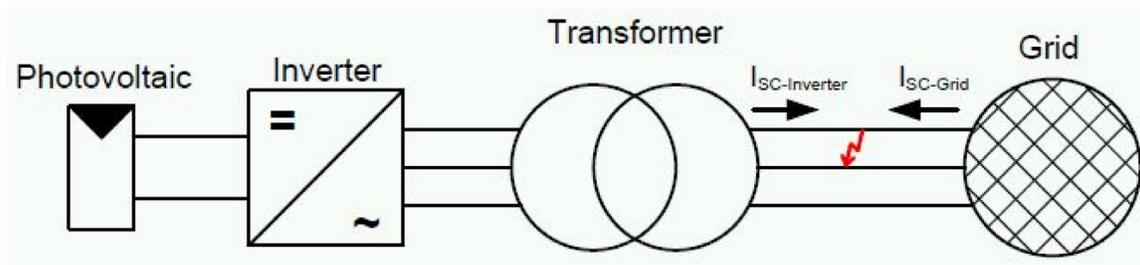

Figure 8—Example of a short-circuit on the power grid side of the transformer

In this case, the main short-circuit current comes from the power grid side of the system. During the short-circuit, the current of the inverter is controlled by the semiconductors, and it is independent of the inverter transformer impedance; initial symmetrical and peak short-circuit currents are equal to or slightly greater (up to 150%) than the inverter nominal current.

- b) Short circuit on the low voltage side of the inverter transformer between an inverter and a transformer (Figure 9).

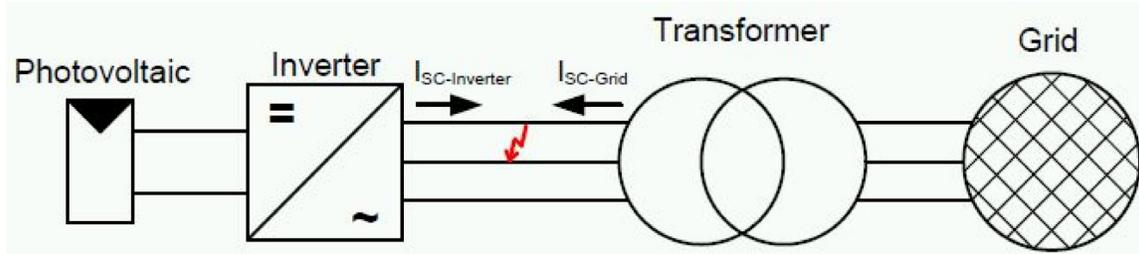

Figure 9—Example of a short-circuit on the low voltage side of the transformer

The main short-circuit current comes from the power grid side and will be limited with the transformer impedance. The inverter short-circuit current is equal to the inverter nominal current.

For the three-winding transformer, the short-circuit considerations in the design of the transformer are fairly standard. Faults may occur on either primary (LV) winding or on secondary (HV) winding.

For the multi-winding transformer, it is recommended to consider the short-circuit currents from each input LV winding to the output HV winding, as well as from both input windings to the output winding. Short-circuit currents need to be considered from one input winding to the other input winding as well. Faults may occur on either one or both of the input windings, as well as on the high voltage output winding. Each of these situations is required to be considered in the design as per current ANSI/IEEE standards.

Winding configuration of the multi-winding transformers affects the magnitude and distribution of the short-circuit forces. These forces and specifics of the mechanical integrity of various winding configurations (e.g., stacked windings case with a short-circuit on one of the LV windings) are important aspects of the reliable design.

5.5.3 Magnetizing inrush current

Inverter transformers can experience a high current inrush when energized. Because DPV inverter transformers can perform step-up or step-down duty, both cases require consideration of expected inrush currents.

The source winding typically carries all of the current with essentially none in other non-connected winding. When a transformer has been taken off-line, there will be a residual flux that remains in the core due to the properties of the magnetic core material. The residual flux may be between 50% and 90% of the maximum operating flux. When a transformer is re-energized, the flux introduced by the source voltage adds to the residual flux in the core. In order to maintain the level of flux in the core, which otherwise may go into saturation, the transformer may draw current in excess of its full-load current. The range of currents may be between four and 40 times the rated full-load current. However, in most transformers this is between seven and 12 times the rated full-load current. This inrush current decays due to the impedance of the magnetic circuit. The decay time can be many cycles. Besides the characteristics of the core material itself and the residual flux, the impedance and air core reactance of the source winding are the limiting factors of the magnetizing inrush current. Therefore, if the source winding is the inner winding of a transformer, located next to the core, the inrush current will be higher than if it is the outer winding of the transformer.

The inrush current can affect the operation of relays, breakers, and fuses in the system connected to the transformer. It also creates near short-circuit type forces within the windings and bus of the transformers. The design of the transformer that will be repeatedly switched off and on needs to take into consideration this aspect of the load. If the transformer is expected to be switched off during periods when the photovoltaic power is not generated, it is recommended to note this in the transformer specification since this could be a daily operation.

Approximation of the inrush current is, generally, not available to the user. Detailed information regarding the inrush current requires detailed design information from a transformer manufacturer. Actual values of inrush current will also depend on where the source voltage of the switching operation occurs, the moment of opening that affects the residual magnetism, and the moment of closing affecting the new magnetizing flux.

Transformers in the string can be energized one after another. Inrush current typically does not cause any significant problems in the systems up to 2 MVA power range.

5.5.4 Electrostatic shield in a transformer

In inverter transformers of the DPV power generation systems, it is recommended to install an electrostatic ground shield between the primary and secondary windings. The user needs to specify the requirements for the shield. Typically, the winding connected to the inverter circuit is ungrounded. The electrostatic ground shield between the primary and secondary windings intended to prevent capacitive coupling of these windings. The main advantage is that the electrostatic ground shield minimizes possible transfer of the high frequency voltage disturbances (harmonics, pulsations, surges that are created in the voltage inverting process) from the primary (LV) winding to the secondary (HV) winding and the power system. The other advantage of the electrostatic ground shield is to reduce a transfer of the high voltage transients (overvoltage) to the primary (LV) windings and the inverter system connected to the primary winding. Without the electrostatic ground shield, a very high percentage of the high voltage transients on the secondary (HV) side may transfer to the primary (LV) side of the transformer. The electrostatic shield also filters the voltage gradient of the pulsed primary (LV) voltage.

The electrostatic shield may greatly increase HV capacitance to ground. Care needs to be taken to prevent series resonance between the leakage reactance of the transformer and the HV capacitance to ground at the commutating frequencies of the inverters.

It is recommended that the design of the electrostatic shield considers the effect of the eddy losses due to the magnetic field. Either aluminum or copper shields can be used. Normally, the thinner the shield metal the less are the eddy losses. Higher conductivity shielding (copper foil) has less eddy losses than lower conductivity (aluminum strip) material.

It is recommended that care be taken in the design and manufacturing of the electrostatic ground shield so as not to create a harmonic heating problem. For example, in the stacked windings arrangement of the three-winding transformer (see [Figure 7c](#)), it is recommended that the electrostatic shield be constructed in two separate parts (top and bottom) in order to avoid additional eddy losses and abnormal temperatures in the situation of the unbalanced loads between two inverters.

The electrostatic shield in L-H space requires full insulation to both adjacent windings. The minimum L-H insulation thickness based on the HV basic impulse level test voltage is increased by the shield thickness plus the minimum LV-to-shield thickness based on the LV basic impulse level voltage. Increased reactance (caused with increased L-H thickness) may require adjustment of a coil build, coil height, and/or coil turns to achieve target impedance.

When present in the transformer, the electrostatic shield is connected to the ground in one single point. The electrostatic shield is grounded to the core/clamp bracket. For liquid-filled transformers, further connection is to the tank/enclosure grounding. External grounding bushing can be specified and connected to, in addition, to

the tank/enclosure grounding, if necessary. The shield should be shown on the nameplate by a dashed line and ground symbol. It may be noted by text as well.

When the electrostatic ground shield is present in the transformer, the insulation power factor test results will be higher than without the electrostatic ground shield. The higher capacitance in the windings tends to increase the apparent insulation power factor, but this is not necessarily an indication of any insulation problem.

For liquid-filled inverter transformers with a high voltage of more than 15 kV that have three-phase, five-leg wound core design, the electrostatic ground shield can also be used between a LV winding and a core leg in order to shield the core leg steel laminates from capacitively induced voltages that could cause a partial discharge in the adjacent oil.

5.6 Technical requirements of auxiliary transformers

An auxiliary transformer is normally used to supply power to the inverter. It can be integrated with the inverter enclosure or be a stand-alone unit (see [Figure 1](#) and [Figure 2](#)).

Generally, an auxiliary transformer is a three-phase transformer that can be connected either to the electricity grid (a) or to the ac output of the inverter (b). In the case (a), the primary voltage of the transformer meets the grid voltage level and the secondary voltage is, for example, 230 V/400 V to connect to the inverter voltage supply. In the case (b), the primary side of the transformer is connected to the pulsed ac output voltage of the inverter with the same secondary voltage as above. In this case, the auxiliary transformer needs to be suitable for work with the voltages and voltage gradients resulting from the pulse mode of the inverter (see [Figure 5](#)). The user specifies the auxiliary transformer voltage parameters.

Normally, an auxiliary transformer is a low kVA rating transformer that can power several inverters. The user specifies kVA rating, connection diagram, and vector group of the transformer.

An auxiliary transformer needs to have a galvanically isolated windings, therefore the autotransformer winding connection is not recommended.

An auxiliary transformer can operate with an asymmetric load of up to 80% and needs to be designed accordingly.

An auxiliary transformer needs to be protected from an overload. The protections to limit short-circuit current and overvoltage at the inverter are used between the inverter and the auxiliary transformer.

6. Transformer general requirements, construction, and protection

6.1 Transformer type

Liquid-filled transformers can use either a transformer mineral oil or a listed less-flammable dielectric coolant meeting the requirements of the National Electrical Code® (NEC®) (NFPA 70®, 2012 Edition), Section 450-23 and the requirements of the National Electrical Safety Code® (NESC®) (Accredited Standards Committee C2-2012), Section 15. When less-flammable liquids with higher viscosity than mineral oil are used, it is recommended to pay a special attention to the transformer thermal design to avoid overheating.

Dry-type transformers can be ventilated Class AA units suitable for outdoor use with an appropriate enclosure per ANSI C57.12.55 or sealed dry-type units in accordance with IEEE Std C57.12.52. Ventilated dry-type transformers can have natural air or forced air cooling.

For both liquid-filled and dry-type transformers, an adequate protection from an adverse effect of moisture, dust, sea site salinity, and other environmental effects, as well as proper insulation distances, need to be demonstrated during a design review.

6.2 Design consideration

The following aspects need to be considered in the design of transformer magnetic core and windings:

- a) *Transformer magnetic core:* Transformers can be designed with wound or stacked core. A three-leg stacked core doesn't have a path for zero sequence magnetic flux; a five-leg stacked or wound core has a path for a zero sequence magnetic flux in the first and the last (fifth) core legs.

In the medium voltage class transformers, hydrogen gas generation may occur in the liquid-filled transformers with shell-form single-phase or five-leg three-phase wound cores in a case where core grounding connections are attached to the outside of the magnetic core surface and transformer has “low-Hhgh” winding arrangement. When such configuration is present, electrostatic coupling from the medium voltage winding to the grounded magnetic steel may be sufficient to raise the potential of the inside core surface to a level where partial discharge and gassing occur between laminations of the magnetic steel. Large amounts of hydrogen gas with smaller amounts of methane, ethane, and ethylene are characteristic of this phenomenon. It is recommended that purchase specification requires that the core grounding connections be placed in a manner to prevent electrostatic coupling of the medium voltage winding with the core. This may be accomplished with grounding connections being placed on the inside of the core stack. Alternative solution to eliminate high core laminates potential differentials is to place a grounded electrostatic shield between the medium voltage winding and the core in the described above designs (see 5.5.4). More details are discussed in Hopkinson [B5].

- b) *Transformer windings:* There are multiple options for the winding design of the transformer. In addition to some configurations discussed in 5.1.5, a configuration with the LV windings located outside of HV winding may also be considered.

6.3 Construction consideration

Liquid-filled transformers are, normally, a compartmental pad-mount design with a dead front. The transformer can be a part of a skid mounted transformer station.

The transformer installation site needs to be clearly specified in order to take into account all specific atmospheric effects: temperature, moisture, level of air pollution, salinity in case of the sea shore installation, elevation, etc.

Often, the transformers are shipped from the manufacturer to an integrator and then to a final site of installation. The final shipment, be on a steel or concrete skid, is different from the one on a wooden pallet. The transformer can be bolted or welded to the integration skid which ultimately impacts the mechanical structure during transportation. Average shipping distance to the DPV power generation system sites can be two to three times farther than what is typical for a conventional transformer, which impacts the mechanical design both internally and externally and needs to be accurately assessed.

Also often, the application sites are in the areas with hot climate, or even deserts, where the extreme ambient temperature fluctuation from a day to a night (for example, 40 °C to 45 °C) can be present. The temperature cycling related to the load fluctuation combined with this ambient temperature fluctuation can lead to significant pressure changes inside the transformer tank of the liquid-filled transformer that are appreciably higher than in traditional distribution transformer applications. This can lead to the daily cycles of pressure from vacuum to an elevated pressure and needs to be considered in the tank and the transformer mechanical structure design to prevent possible failures from the material mechanical fatigue.

It is recommended that the initial tank pressure be set at the time of commissioning based on the top fluid and ambient temperature.

It is recommended to carefully define the necessary liquid level in the liquid-filled transformer, taking into account the oil volume change with the wide range of the described above temperature variations, especially in cases of the cold starts from the de-energized condition. The liquid drop below the level covering switches and other accessories can lead to electrical or thermal failures. Added liquid level to fully cover switches and accessories in all possible conditions can be specified.

6.4 Recommended accessories and gauges placement

The required accessories are specified by the user based on the protection and maintenance practices.

The user needs to recommend preferred location for gauges. Because of the arc flash concerns (see 6.5), gauges are often not placed in the LV compartment. Gauges can be exposed to the environment or be located in a separate locked “gauge cabinet.”

The accessories list of liquid-filled transformers may include the following devices: drain valve with filter and sampler, top oil thermometer with contacts, fluid level gauge with contacts, pressure/vacuum gauge with contacts, pressure relief device, Schrader valve, load break switch, secondary (HV) side weak link fuse, partial range current limiting fuses, optional neutral bushings, top filling port with a plug, and arc flash detectors.

The fuses need to be properly sized and coordinated with the upstream relays in the high voltage switch gear. The partial range and weak link fuse coordination is typically selected based on the full kVA rating of the transformer. However, should a fault occur in the low voltage winding in a design with multiple LV windings per phase, the HV to LV kVA rating can be only 50% of the nameplate rating. As a result, the fuse clearing time could be longer than desired as the selection is less than was considered optimum in the system design.

As DPV power generation system project scale has increased over time and moved from a distribution to a transmission level, 34 500 V has become common on HV side, which impacts the type of over-current protection (bayonets versus internal cartridge fuses).

6.5 Arc flash aspects and protection

Some maintenance activities require de-energization of the transformer, for example, switching the transformer in and out of the collection circuit, taking oil samples for a routine test, monitoring tank pressure and adding gas as needed, infrared (IR) scans of HV and LV terminations, and preventive de-energization of the system for maintenance. Incident energy at load break operation can be high on both LV and HV terminals being significantly higher on LV terminals.

The arc flash energies inside the transformer compartments may reach sufficiently high levels that industry safety standards may not permit some type of work in the energized compartments. It is recommended to perform arc flash studies and work task analysis to aid in the design of an electrical system that limits arc flash incident energy levels and worker exposure to energized parts.

Such devices as a transformer disconnect switch (for both dry-type and liquid-filled transformers), oil sampling valve, tank pressure gauge, and gas connection (for liquid-filled transformer) are sometimes required to be relocated outside of the traditional transformer compartment. As the transformer can be located in non-secured areas, the access to these devices may require tamper-proof enclosures.

7. Transformer test, installation, and commissioning

7.1 Testing

Unless otherwise specified, tests are made at the factory only. Routine and type tests performed on a DPV power generation system inverter transformer are as identified in IEEE Std C57.12.00 for liquid-filled transformers and IEEE Std C57.12.01 for dry-type transformers, except as recommended below.

Load loss test: Load loss is determined by the methods given in IEEE Std C57.12.90 for liquid-immersed and in IEEE Std C57.12.91 for dry-type units, with special considerations listed below. The measurement of load losses is performed with sinusoidal rated transformer current. The load loss guarantee is based on the sinusoidal loss measurement, for commercial purposes.

In case a harmonic correction needs to be considered, it is recommended that the user specifies the harmonic spectrum to be used for load loss evaluation. This spectrum may be different from the one specified for the temperature rise test, which represents the worst case operating conditions.

Actual service load loss for the expected harmonic spectrum provided in the specification to the transformer manufacturer with the inquiry may also be calculated and submitted for information in the bid proposals. These losses are not subject to guarantee but are calculated according to accepted methods, an example of which is described in IEEE Std C57.18.10, clause on Testing and Calculations.

Temperature rise test and thermal study: Recommendations on the thermal study taking the harmonic content into account can be found in IEEE Std C57.129. Specifically, this standard discusses that, in some cases, standard power transformer loading tables may not be used for loading determination because of the effect of the harmonic currents and dc bias on the converter (inverter) connected windings.

Test voltage: If considered necessary, the user may specify an enhanced high voltage test to compensate possible voltage fluctuation and transient overvoltage (for example, specify the test for the next higher voltage class level). This approach can also be used in case of the unusual site conditions like sea shore installation. Impulse test of the primary (LV) winding is recommended.

Partial discharge (PD) inception/extinction test: This test is a design test for all dry-type transformers and a routine test for dry-type transformers above 1.2 kV having solid cast windings as a part of insulation system (test procedure and criteria are in IEEE Std C57.12.01). This test may also be used for liquid-filled transformers; the partial discharge value below 100 pC at the last step of the test can be considered a criterion of acceptance in this case.

Impedance test: Unless otherwise specified, it is recommended to perform the test at the nominal tap. IEEE Std C57.18.10 provides guidance on the impedance test in the multi-winding transformer. If requested by the user, a manufacturer must measure the impedance and load loss for the following tests: L1L2-H (both LV windings are short-circuited, HV winding is energized), L1-H and L2-H (one LV winding is short-circuited, HV winding is energized), L1-L2 (one LV winding is short-circuited, other LV winding is energized).

7.2 Installation and commissioning

Installation and commissioning of the DPV power generation system transformers follow the recommendations outlined in IEEE Std C57.93 for liquid-filled transformers and IEEE Std C57.94 for dry-type transformers.

As discussed in 6.3, it is recommended that for the liquid-filled transformers the initial tank pressure be set at the time of commissioning, based on the top fluid and ambient temperature.

8. Transformer maintenance, diagnostic, and monitoring

Typically it is recommended to perform maintenance in accordance with IEEE Standards and additional recommendations of the transformer manufacturer's maintenance guide.

During major equipment clearances, it is recommended to have pad lighting and convenience receptacles for maintenance activities.

As discussed in 6.3, depending on certain design parameters of the liquid-filled transformers, it might be necessary to reset the internal pressure to keep it within a reasonable working range.

Periodical insulating liquid DGA testing is recommended.

Partial discharge measurement and other diagnostic methods maybe utilized as necessary (Shertukde [B20]).

9. Transformer specification

It is recommended that the end user, system designer, inverter specialist, and transformer specialist collaborate on the specification of the transformer parameters, assuring all important aspects of the application are properly specified. System and power quality studies can be considered to confirm system related requirements. The user is responsible for completing the data sheets for equipment specifications to make them project specific.

The user ensures that all requirements contained in the system and inverter specifications and applicable documents are met, including protection requirements, required equipment tests, pre-energization tests, and submittal requirements.

In addition to the standard transformer parameters, the following characteristics may be required to be specified for the DPV power generation system transformer design:

- Maximum continuous kVA rating based on the maximum inverter output.
- Requirements on the step-up, step-down (reverse power flow) capability.
- Voltage class and test voltages, including LV impulse test, if any.
- Current harmonic content needs to be specified or reference needs to be made to IEEE Std C57.12.00 or IEEE Std C57.12.01.
- Required impedances and respective tolerances (with indication of the respective reference power value). Example: $I_Z (L1-H) = 4.7\% (\pm 10\%)$ based on 50% of a transformer nominal kVA rating.
- Typical daily load profiles, showing the mean and extreme load conditions (e.g., related to the weather change), so that the design can be optimized (plus load profile as a function of the ambient temperature).
- Number and typical schedule of energize/de-energize operations. If switching is required daily, it is advisable to define parameters of the transient overvoltage and overcurrent.
- Maximum tank pressure for liquid-filled or sealed dry-type transformers.
- Transformer installation site description (including climate, salinity, possible air contaminants).
- Maximum ambient temperature range per day, per month, and per year.
- Electrostatic shield requirements.
- Power factor information.
- Possible dc bias current, if any (data supplied by an inverter manufacturer).
- List of the required accessories and gauges and their recommended placement.
- Arc flash protection requirements.

Annex A

(informative)

Bibliography

Bibliographical references are resources that provide additional or helpful material but do not need to be understood or used to implement this standard. Reference to these resources is made for informational use only.

[B1] Betancourt, E., “Tutorial on DPV Transformers”, (presentation, IEEE Transformer Committee Meeting, Munich, Germany, March 2013).

[B2] Buckmaster, D., P. Hopkinson, and H. Shertukde, “Transformers used with Alternative Energy Sources—Wind & Solar,” (presentation, IEEE Transformer Committee Meeting, Apr. 11, 2011).

[B3] California Energy Commission (CEC) Standard on Electrical System Efficiency.

[B4] DOE 10CFR Part III US Department of Energy (DOE) Final Rule for Commercial Equipment: Distribution Transformers Energy Efficiency, 10 CFR Part 431 Federal Register / Vol. 72, No. 197 / October 12, 2007 / Rules and Regulations.⁹

[B5] Hopkinson, P., “WG PC 60076 on Wind Power Transformers,” IEEE Transformer Committee. (presentation St. Louis, MO, March 2013).

[B6] IEC 60071-2:1996, Insulation Coordination - Part 2: Application Guide,” Annex - E – “Transferred Over-Voltages in Transformers.”¹⁰

[B7] IEC 60076-16, Power Transformers – Part 16: Transformers for Wind Turbine Application.

[B8] IEEE Std C57.12.80, IEEE Standard Terminology for Power and Distribution Transformers.^{11,12}

[B9] IEEE Std C57.116, IEEE Guide for Transformers Directly Connected To Generators.

[B10] IEEE Std C57.142, IEEE Guide To Describe the Occurrence and Mitigation of Switching Transients Induced by Transformers, Switching Device, and System Interaction.

[B11] IEEE Std 62, IEEE Guide for Diagnostic Field Testing of Electrical Power Apparatus – Part 1: Oil Filled Power Transformers, Regulators and Reactors.

[B12] IEEE Std 519, Recommended Practices and Requirements for Harmonic Control in Electrical Power Systems.

[B13] IEEE Std 1547, IEEE Standard for Interconnecting Distributed Resources and Electric Power Systems.

[B14] IEEE TF on DPV Transformers, White Paper “Considerations for Power Transformers Applied in Distributed Photovoltaic (DPV)—Grid Application,” (presentation, IEEE Transformer Committee Meeting, San Diego, CA, Apr. 10-14, 2011).

⁹CFR publications are available from the U.S. Government Publishing Office, P.O. Box 979050, St. Louis, MO 63197-9000, USA (<http://www.ecfr.gov/>).

¹⁰IEC publications are available from the International Electrotechnical Commission, 3, rue de Varembe, P.O. Box 131, CH-1211 Geneva 20, Switzerland (<http://www.iec.ch/>). IEC publications are also available in the United States from the American National Standards Institute, 11 West 42nd Street, 13th Floor, New York, NY 10036, USA (<http://www.ansi.org/>).

¹¹IEEE publications are available from the Institute of Electrical and Electronics Engineers (<http://standards.ieee.org/>).

¹²The IEEE standards or products referred to in this clause are trademarks of the Institute of Electrical and Electronics Engineers, Inc.

[B15] Jordaan, C., “Transformers for Application in Distributed Photovoltaic (DPV) Power Generation Systems,” (presentation, IEEE Transformer Committee Meeting, Munich, Germany, March 2013).

[B16] PV Grid Integration: Background, Requirements and SMA Solutions, 4th edition, revision of May 2012.

[B17] Rasheek, R., “Consideration in Modeling and Applications of Three Winding Transformers in Industrial and Commercial Facilities,” (presentation, Industrial and Commercial Power Systems Technical Conference, 2010).

[B18] Rasheek, R., “Modeling and Applications of Three Winding Transformers in Industrial and Commercial Facilities. Part 2: Unbalanced and Transient Analysis,” (presentation, Industry Application Society Annual Conference, 2011).

[B19] Rasheek, R., “Switching and Protection of Multiple Transformer Arrangement in Industrial Distribution System,” (presentation, Industrial and Commercial Power Systems Technical Conference, 2013).

[B20] Shertukde, H., “Distributed Photovoltaic (DPV)-Grid Transformer Applications,” CRC Press, a Taylor and Francis Group, 2014.

[B21] UL 1741, A Safety Standard For Distributed Generation.¹³

¹³UL standards are available from Underwriters Laboratories, 333 Pflugsten Road, Northbrook, IL 60062-2096, USA (<http://www.ul.com/>).

Consensus

WE BUILD IT.

Connect with us on:



Facebook: <https://www.facebook.com/ieeesa>



Twitter: @ieeesa



LinkedIn: <http://www.linkedin.com/groups/IEEESA-Official-IEEE-Standards-Association-1791118>



IEEE-SA Standards Insight blog: <http://standardsinsight.com>



YouTube: IEEE-SA Channel

IEEE
standards.ieee.org

Phone: +1 732 981 0060 Fax: +1 732 562 1571

© IEEE